

BEYOND  **BATTERIES™**

HD Range

**Lithium-ion - Heated LiFePO4 batteries.
With remote & local monitoring systems.**



Information Booklet

Contents

- Benefits and Features:..... 3**
 - Model Specifications:..... 4
- Safety precautions..... 5**
 - Hazard Identification and First Aid Measures..... 6
- Measurements (maximum dimensions)..... 7**
 - HD100..... 7
 - HD160..... 7
 - HD200..... 8
 - HD300..... 8
 - HD460..... 9
- Usage..... 9**
- Usage Precautions..... 10**
- What's Included..... 10**
- Technical Data..... 11**
- Characteristic Graphs..... 13**
- Warranty..... 14**
- Transportation..... 15**
- Certifications..... 16**
- Notes..... 17**
- Our Mission..... 18**



Benefits and Features:

- **Stable Chemistry:** Reduces the risk of overheating and combustion.
- **Thermal Stability:** Handles higher temperatures without compromising safety.
- **Extended Longevity:** Provides over 6,000 charge/discharge cycles.
- **Durable Performance:** Maintains capacity and efficiency over many years.
- **Efficient Charge/Discharge:** Up to 95% efficiency in energy use.
- **Minimal Energy Loss:** Maximises the utility of stored energy.
- **Reliable Voltage:** Delivers stable voltage throughout the discharge cycle.
- **High Discharge Rates:** Suitable for high-power applications.
- **High Energy Density:** Packs more energy into a smaller footprint.
- **Reduced Weight:** Easier to handle and install compared to traditional batteries.
- **Quick Recharge:** Shorter charging times for more uptime.
- **High Current Acceptance:** Handles high currents without damage.
- **Non-Toxic Materials:** Free from harmful heavy metals.
- **Eco-Friendly Disposal:** Easier and safer to recycle.
- **Extended Shelf Life:** Retains charge longer when not in use.
- **Ready to Use:** Less frequent need for recharging during storage.
- **Operational Versatility:** Performs well in extreme temperatures from -20°C to +60°C.
- **Reliable in Various Conditions:** Suitable for both hot and cold environments.
- **Modular Design:** Easily scalable for different energy requirements.
- **Flexible Applications:** From small residential systems to large industrial setups.
- **No Regular Upkeep Needed:** Low maintenance compared to other battery types.
- **Cost Savings:** Reduces operational and maintenance costs over time.

Model Specifications:

Model	Type	Length (mm)	Width (mm)	Height (mm)	Weight (kg)	Charge time (hrs) (A range)	Continuous (A)	Peak (A)
		(Base/Minimum) / (Top/Handles/Maximum)						
HD100	12.8V 100Ah	253/259	157/171	213*/224**	9.7	5-1 (20-100A)	100	200
HD160	12.8V 160Ah	320/330	160/172	220*/231**	14.8	4-1 (40-160A)	200	400
HD200	12.8V 200Ah	448/500	166/186	244*/253**	18.6	5-1 (40-200A)	250	500
HD300	12.8V 300Ah	348/385	184/204	272*/283**	27	5-1.2 (60-250A)	250	500
HD460	12.8V 460Ah	480/520	247/266	223*/234**	38.1	5.75-1.84 (80-250A)	250	500

*top of case, **top of communications port

The HD300 is currently available only in the heated size of 385×204×283. The heated version with a communications port is available in the 525×242×224 size.

Safety precautions

To ensure the life cycle of the battery and for safe use the following must be adhered to:

- The battery must not be charged or discharged with a higher current than recommended.
- The battery must be kept away from heat, sparks and hot surfaces.
- The battery must not be exposed to open flames.
- The battery must be stored away from incompatible materials and foodstuffs.
- The battery must not be stored in high temperature locations, in direct sunlight or left inside a vehicle in hot weather.
- The battery must not be short circuited.
- Precautionary measures must be made against static discharges.
- The battery should not be subject to forceful impacts and the casing must not be penetrated.
- The battery cells must not be exposed to water.
- The battery must not be disassembled or modified.
- The battery must not be placed in the vicinity of microwave radiation, or electrical induction equipment.
- In the event of fire, suitable extinguishing media can be plenty of water, dry chemical, carbon dioxide or alcohol resistant foam.
- The battery must not be used by, or left unattended with children.
- The battery must only be used in line with the temperature range it is designed to be charged or discharged at. Use outside this may damage the battery, affect performance and reduce its life cycles.
- The battery must only be charged using a LiFePO4 charger.
- When charging, the battery must not be left unattended or when charging for long periods.
- When fully charged the battery charger must be disconnected from the terminals and the mains power supply.
- The charging premises must have an appropriate fire detection and alarm system and appropriate fire prevention equipment.
- Any abnormal change to the battery, use must cease immediately, this includes but not exclusive to heat, smell or shape.
- The battery charge state should be checked regularly and must be recharged to 80% at least every three months when in storage.
- The battery must be disposed of in accordance with governmental and local regulations.
- The battery is not able to be transported on passenger flights.



Hazard Identification and First Aid Measures

LiFePO4 Batteries are not hazardous when used according to the instructions of the manufacturer under normal conditions. In case of abuse, there is a potential hazard of rupture, fire, heat, leakage of the internal components, which could cause injury. Abuses including but not limited to the following cases: over charged for long time, persistent overvoltage, short circuited, put into fire, impact with hard object, punctured with acute objects, crushed, and broken.

In the unlikely event of exposure or injury from the battery, follow the following First Aid measures:

Eye	Flush eyes with plenty of water for at least 15 minutes, occasionally lifting the upper and lower eyelids. Seek immediate medical assistance.
Skin	Remove contaminated clothes and rinse skin with plenty of water or shower for 15 minutes. Seek immediate medical assistance.
Inhalation	Remove from exposure and move to fresh air immediately. Use oxygen if available. Seek immediate medical assistance.
Ingestion	Induce vomiting unless the patient is unconscious. Seek immediate medical assistance.

Measurements (maximum dimensions)

HD100

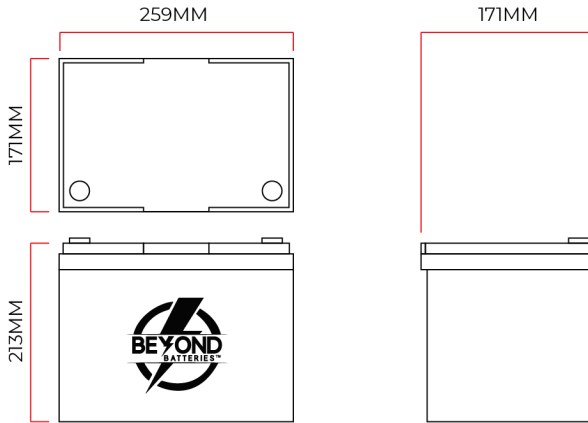

HD160

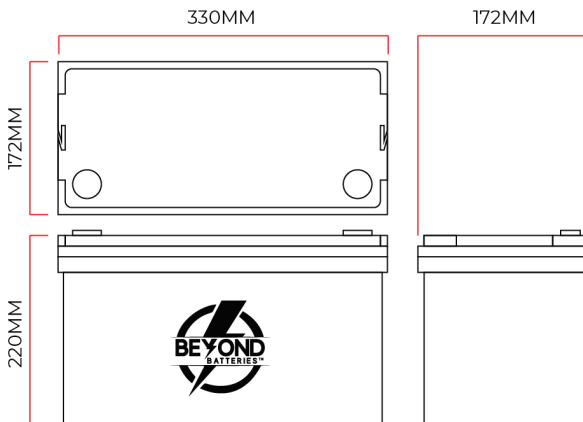

HD200

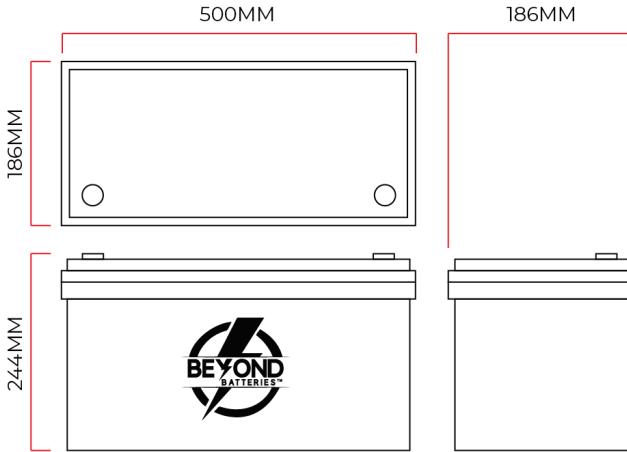

HD300

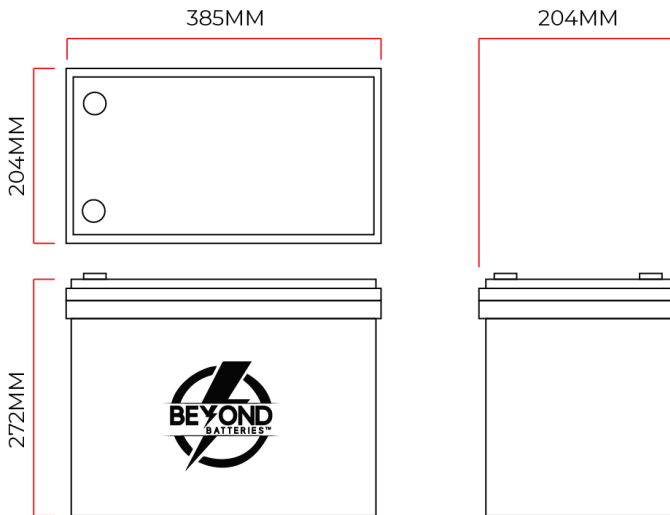

HD460

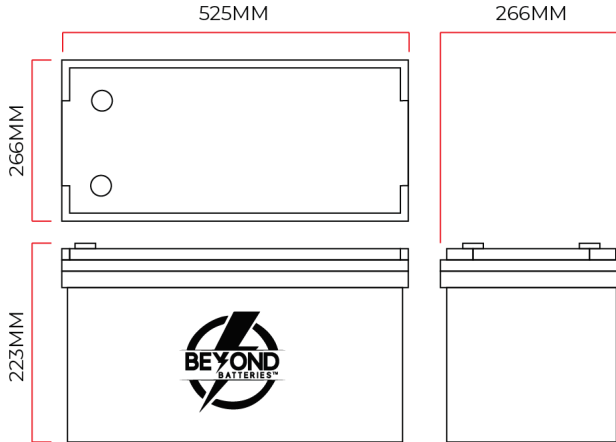

Usage

These LiFePO4 batteries are designed for user convenience, featuring colour-coded terminals for easy identification. They come with all the necessary hardware, including M8 bolts, washers, and sprung washers. The batteries are versatile, capable of powering a wide range of 12V DC equipment. Additionally, when paired with a suitable inverter, they can be used to power AC devices

Beyond Batteries LiFePO4 range is Bluetooth Enabled to allow Smartphone monitoring via a Smartphone or Tablet App.

To download the app for Android or iOS please use the following link:



Usage Precautions

- Ensure the correct charger type is used when charging LiFePO4 Batteries..
- When storing the battery, ensure it's in a charged state. Recharge every 3 months.
- It is recommended to recharge LiFePO4 batteries within 12 hours if it has been fully discharged.
- Charging temperature range: 0°C to 60°C
- Discharging temperature range: -20°C to 60°C
- Excessive heat can degrade the battery cells. Always store your battery in a cool, dry place.
- Avoid leaving the battery for extended periods in direct sunlight or in a hot vehicle.
- Avoid immersing your battery in water.
- Do not dispose of the battery pack in regular household waste.
- Do not try to disassemble the battery under any circumstances.
- Avoid short-circuiting the battery as it may lead to overheating, despite its protective measures.
- Do not utilise the battery for cranking or starting engines.

What's Included

- Beyond Batteries HD Range LiFePO4 battery in the size purchased.
- 2 x M8 Stainless steel connection bolts, washers and sprung washers
- 1 x User manual

Technical Data

MODEL	HD100	HD160	HD200	HD300	HD460	NOTES
CE MARKING	BB12-100HDna	BB12-160HDna	BB12-200HDna	BB12-300HDna	BB12-460HDna	
RATED CAPACITY	100Ah	160Ah	200Ah	300Ah	460Ah	25±2°C
NOMINAL VOLTAGE	12.8V					
TOTAL ENERGY	1280Wh	2048Wh	2560Wh	3840Wh	5888Wh	
CHEMISTRY	LiFePO4					
CELL TYPE	Prismatic					
MAXIMUM CONTINUOUS DISCHARGE CURRENT	≤100A	≤200A	≤250A	≤250A	≤250A	
PEAK DISCHARGE CURRENT	≤200A	≤400A	≤500A	≤500A	≤500A	@3 seconds
MAXIMUM CHARGE CURRENT	≤100A	≤160A	≤200A	≤250A	≤250A	@25°C
RECOMMENDED CHARGE CURRENT	20A	40A	40A	60A	80A	
RECOMMENDED CHARGE PROFILE	CC / CV (Constant current / constant voltage)					
RECOMMENDED CHARGE VOLTAGE	14.4V					
MAXIMUM CHARGE VOLTAGE	14.6v					
UNDER VOLTAGE DISCONNECT	10V					
USABLE TEMPERATURE WINDOW	-20°C~60°C					
CHARGING TEMPERATURE	If the cell pack drops to 2°C, the charger activates the heater before charging begins. The heater turns off once the temperature reaches 5°C. Normal charging range:					-10°C~45°C

WINDOW	2-45°C.					
TERMINAL CONNECTIONS	M8					
CASE TYPE	ABS Plastic IP65 rated					
CERTIFICATIONS	UKCA, CE, UN38.3, RoHS					
BASE DIMENSIONS (L*W) (mm)	253*157	320*160	448*166	348*184	480*248	Battery base
TOP DIMENSIONS (L*W*H) (mm)	259*171*213	330*172*220	500*186*244	385*204*272	525*266*223	Widest points (Top/Handles)
HEIGHT WITH TERMINALS (mm)	224	231	255	283	234	No items attached
WEIGHT (kg)	9.7	14.8	18.6	27	38.1	
SMART BMS	100A	200A	250A	250A	250A	
BLUETOOTH	Yes					
CONNECTIVITY	Canbus, VE.Can, RS485					RJ45 interface
STORAGE TEMPERATURE	-10°C~30°C					
SHIPPING CLASSIFICATION	UN3480 - Class 9					
CONFIGURATION AND EXPANSIONS	16 x parallel, 4 x series to 51.2V max					
SELF DISCHARGE PER MONTH	< 3%					

Battery sizes, ports, and terminal positions are subject to change.

Characteristic Graphs

Temperature effect on discharging (0.5C)

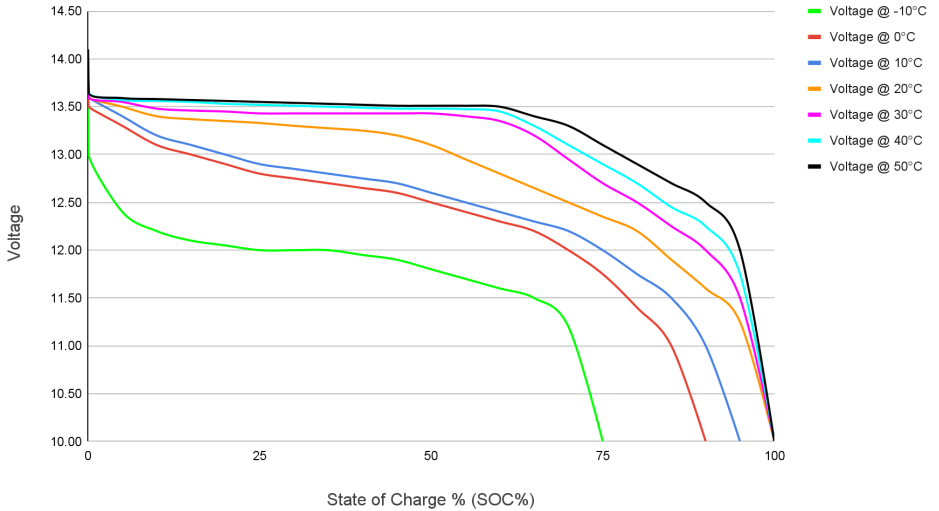

Charging characteristics at different rates

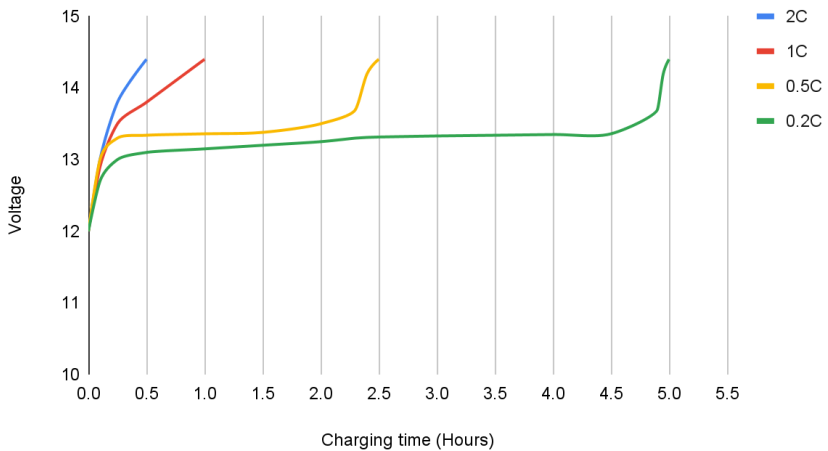

Warranty

Terms and Conditions:

This Limited Warranty ("Warranty") is provided by Beyond Batteries Ltd ("the Company") for the Beyond Batteries™ HD Range ("the Product"). This Warranty is valid only within the United Kingdom and is subject to the following terms and conditions:

1. Warranty Period:

The Warranty period for the Product shall commence from the date of purchase by the original purchaser and shall extend for twenty four (24) months thereafter ("Warranty Period").

2. Coverage:

During the Warranty Period, the Company warrants that the Product shall be free from defects in materials and workmanship under normal use and service. This Warranty covers only manufacturing defects and does not cover any damage caused by misuse, abuse, negligence, accidents, unauthorised modifications, or natural disasters.

3. Remedy:

If the Product is found to be defective during the Warranty Period, the Company will, at its sole discretion, repair or replace the defective Product, or refund the purchase price of the Product. The Company reserves the right to use new or refurbished parts or units in performing warranty services.

4. Claim Procedure:

To make a warranty claim, the original purchaser must contact Beyond Batteries Ltd Customer Service within the Warranty Period. Proof of purchase, including the date and location of purchase, may be required to validate the claim. The Product must be returned to the Company, at the purchaser's expense, in accordance with the instructions provided by Customer Service.

5. Exclusions:

This Warranty does not cover:

- Damage resulting from accidents, misuse, abuse, or negligence.
- Unauthorised modifications or repairs.
- Standard wear and tear, including gradual capacity decline over time.
- Improper storage, handling, or maintenance.
- Using the carry case for purposes other than its intended use.
- Warranty will be voided if the battery remains fully discharged for an extended period.
- Warranty will be voided if the void sticker affixed to the product is broken or tampered with.
- Using the battery with incompatible devices or chargers.
- Not adhering to recommended charging and usage instructions.
- Exposure to extreme temperatures or environmental conditions beyond specified limits.
- Physical damage such as punctures, cracks, or impacts.
- Failure to provide proof of purchase or warranty registration.
- Force majeure incidents such as natural disasters, accidents, or power surges.
- Damage caused by third-party products or accessories used alongside the battery.
- Not following maintenance recommendations outlined in the product manual or guidelines.
- Natural degradation of the battery over time and with usage.

6. Limitation of Liability:

To the maximum extent permitted by law, the Company shall not be liable for any indirect, incidental, special, or consequential damages arising out of or related to the use or inability to use the Product, even if advised of the possibility of such damages.

7. Consumer Rights:

This Warranty does not affect the statutory rights of consumers under applicable laws in the United Kingdom.

8. Governing Law:

This Warranty shall be governed by and construed in accordance with the laws of the United Kingdom.

9. Entire Agreement:

This Warranty constitutes the entire agreement between the parties with respect to the subject matter hereof and supersedes all prior agreements and understandings, whether written or oral, relating to such subject matter.

10. Contact Information:

For warranty claims or inquiries, please contact Beyond Batteries™ Customer Service:

Phone: +441273921129

Email: info@beyondbatteries.co.uk

Transportation

LiFePO4 batteries are classified under UN3480 (lithium-ion batteries) or UN3481 (lithium-ion batteries contained in or packed with equipment). Numerous regulations govern the transportation of lithium batteries. For further details, we recommend consulting your local carrier, Airline or IATA.

Certifications

RoHS compliant

RoHS compliance means that a product meets the requirements of the Restriction of Hazardous Substances (RoHS) Directive.

<https://www.gov.uk/guidance/rohs-compliance-and-guidance>



The presence of the CE logo on commercial products indicates that the manufacturer or importer affirms the goods' conformity with European health, safety, and environmental protection standards.

<https://www.gov.uk/guidance/ce-marking>



UKCA stands for UK Conformity Assessment. It's a marking that indicates a product meets the requirements to be sold in Great Britain (England, Scotland, and Wales).

<https://www.bsigroup.com/en-IL/Our-services/Product-certification/ukca-mark/>

UN38.3

UN 38.3 is a United Nations (UN) standard that outlines the requirements for safely transporting lithium batteries. The standard applies to all lithium batteries, whether they are used in devices or transported on their own.

https://unece.org/fileadmin/DAM/trans/danger/ST_SG_AC.10_11_Rev6_E_WEB_-With_corrections_from_Corr.1.pdf

Our Mission

Help the planet to generate and store energy, one small off-grid set up at a time, by working with our business partners to understand their needs, build bespoke solutions and proactively develop products for organisations before they even know they need it.

***Our batteries go beyond and so do we.
Beyond Batteries.***

Last updated: 18/07/2025

Version: 1.4

Contact Information:

Email: info@beyondbatteries.co.uk

Phone: +44 (0) 1273 921 129

Address: 9 Sutton road, Seaford, East Sussex, BN25 1RU