

# **Earth Anchor (Ground Screws and Augers) Installation Guidelines**

# Earth Anchor Installation: Introduction

## Installation Methods:

Ground Screws and Blade Augers can be installed quickly in a wide variety of soil conditions using a variety of skid steers, excavators, tractors and even self-propelled drilling rigs. These Earth Anchors are ready for loading immediately after installation which makes them ideal for one day PV installations. This document is intended to provide general information regarding SunModo's Ground Screws and Blade Augers.



# Earth Anchor Installation: Product Specification

BASIC INFORMATION	
Kit Number	K10414-079
Description	10" Helix Blade Auger
Lengths (-079)	79 inches
Auger Diameter	2.72" [69mm] ID 2.99" [76mm] OD
Attachment Hardware	3X M16 Set Screws Use 8mm Hex Driver
Material	#45 Structural Carbon Steel
Finish	Hot Dip Galvanized
Approximate Weight	18.1 lbs [8,2 kg] 23.1 lbs [10,5 kg]

BASIC INFORMATION	
Kit Number	K10423-XXX
Description	Screw Anchor
Lengths (-063   -080)	63 inches   80 inches
Auger Diameter	2.72" [69mm] ID 2.99" [76mm] OD
Attachment Hardware	3X M16 Set Screws Use 8mm Hex Driver
Material	#45 Structural Carbon Steel
Finish	Hot Dip Galvanized
Approximate Weight	18.1 lbs [8,2 kg] 23.1 lbs [10,5 kg]

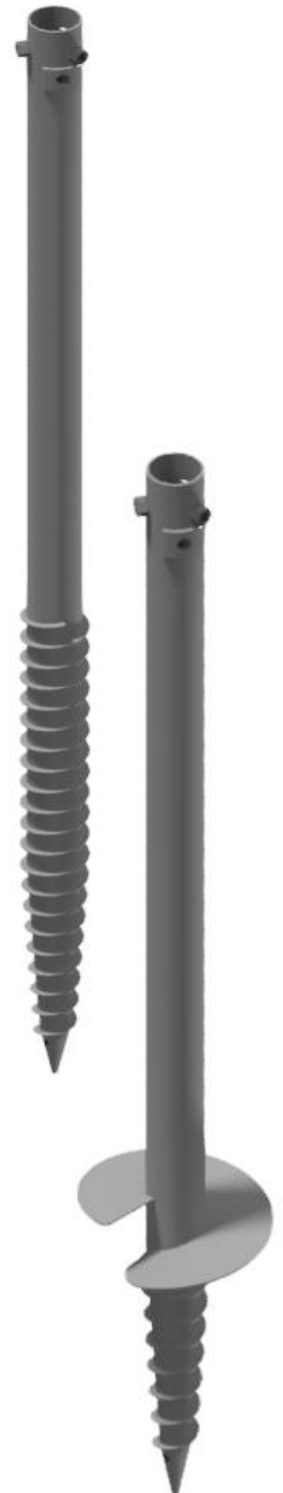

# Earth Anchor Installation: Product Specification

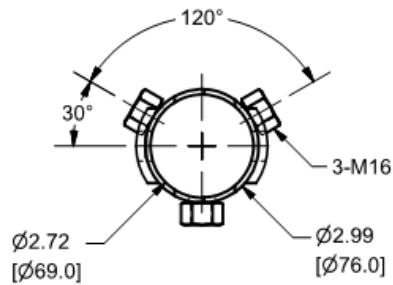

TYPICAL DETAIL

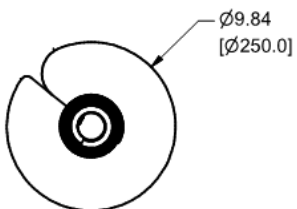
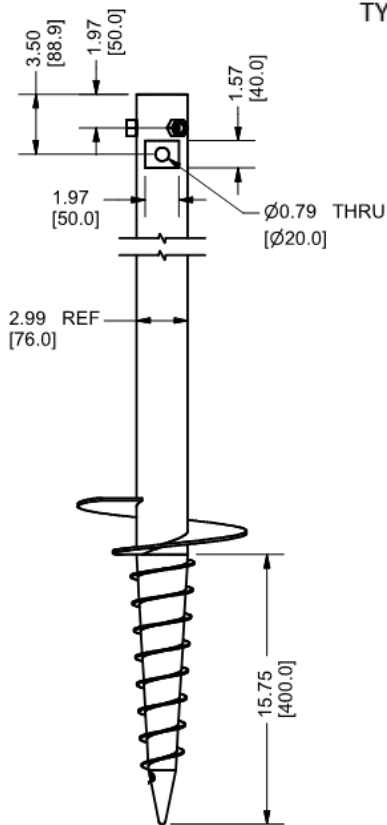

A21178-XXX

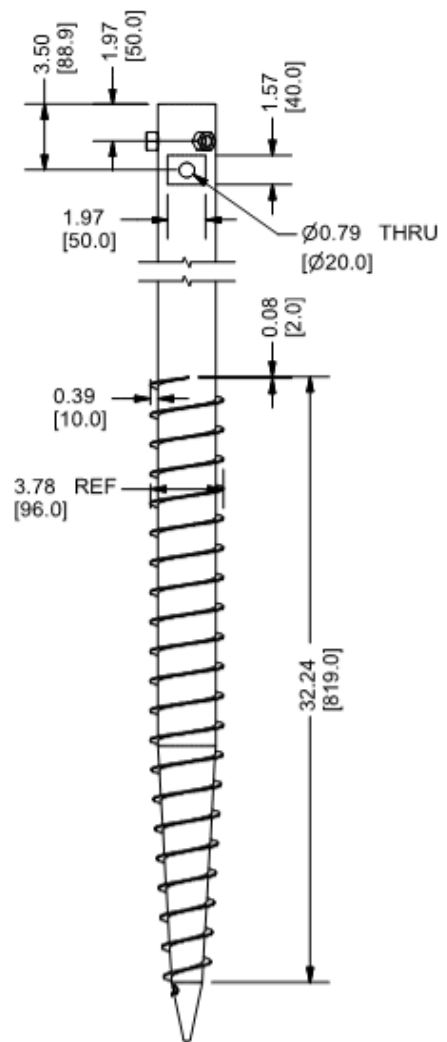

A21147-XXX

# Earth Anchor Installation: Best Practice

These anchors are used for securing installer-supplied 2-inch Schedule 10 or 40 galvanized steel pipe. Our anchors are popular because they are strong, economical, and easily to install. Our newest anchors are supplied with M16 Cone-tipped Set Screws which provides a superior grip onto the post.

## Installation Guidelines for A21146-XXX and A21147-XXX:

- Determine the anchor locations per SunModo project requirements. Build two pairs of batter boards to hold the mason's lines: one pair for the front posts and the other for the rear posts.
- Make sure the top ends of the front and rear Anchors are at the same height (within 1" high difference).
- Install the front/rear Post to the Anchors as shown and secure with 3X M16 Set Screws using 8mm Hex Driver; torque to 44 ft. lbs. (60 Nm).
- Install M16 Bolt and Flange Nut if required in the 4X corner posts of the array.

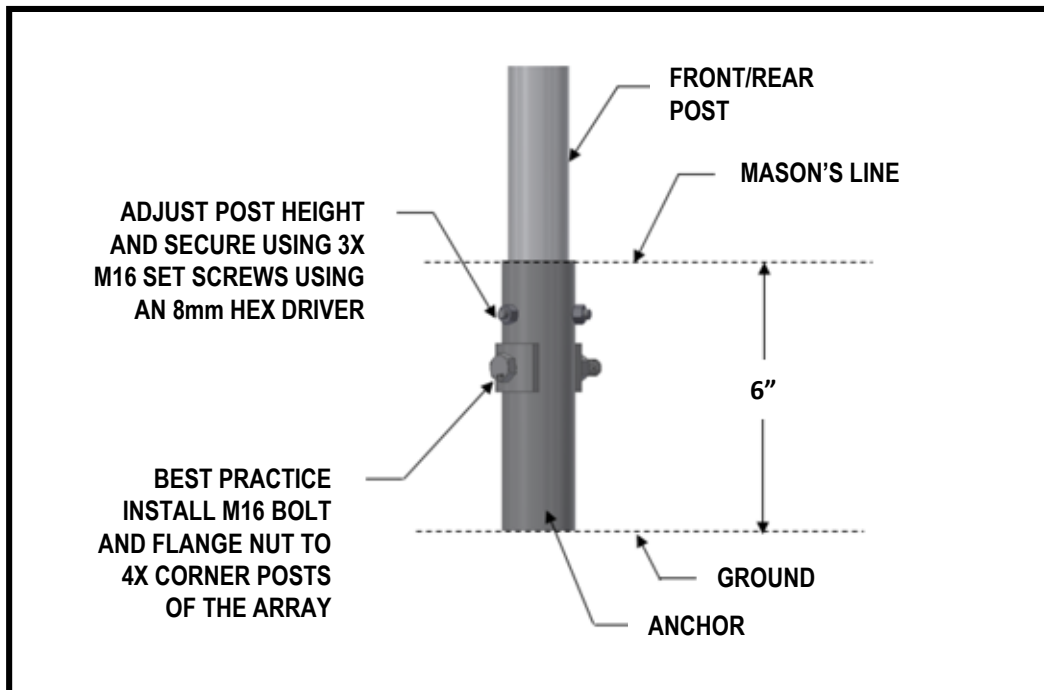

# Earth Anchor Installation: Machine Operated Rotator

1. THESE INSTALLATION INSTRUCTIONS ARE OF A GENERAL NATURE AND COVER THE MOST COMMON CONDITIONS AND SITUATIONS.
2. FOLLOW THE SAFETY PRECAUTIONS PROVIDED BY THE EQUIPMENT MANUFACTURERS BEFORE ATTEMPTING TO INSTALL THE EARTH ANCHORS.
3. THESE SAFETY PRECAUTIONS ARE INTENDED TO DEAL PRINCIPALLY WITH COMMON PRACTICES AND CONDITIONS ENCOUNTERED IN THE USE OF THE BOBCAT® (OR SIMILAR EQUIPMENT) AND ARE NOT INTENDED TO BE ALL INCLUSIVE. PROPER LEVELS OF INSTALLATION EXPERIENCE, SKILL AND COMMON SENSE ARE ESSENTIAL FOR SAFE AND EFFICIENT INSTALLATION.
4. BOBCAT COMPANY OFFERS A VARIETY OF TRAINING AND SAFETY RESOURCES FOR OWNERS, RENTERS AND OPERATORS. BE SURE TO SEE THE OPERATOR TRAINING COURSES THAT ARE AVAILABLE ONLINE. THESE SELF-PACED, INTERACTIVE COURSES ARE FULLY RESPONSIVE SO TRAINEES CAN LEARN ON THE DEVICE OF THEIR CHOICE.  
<https://www.bobcat.com/owners/safety-training/resources/courses>



## SAFETY



Do Not  
Operate  
Indoors



Safety Shoes  
Required



Call 811 Dig  
Safe Before  
Digging



Gloves  
Required

# Earth Anchor Installation: Auger – Bobcat 15C

## Bobcat 15C Auger:

This high-torque, heavy-duty hydraulic auger fits directly into the SunModo Ground Screws and Augers without the need for an adaptor.



## Weights and Dimensions:

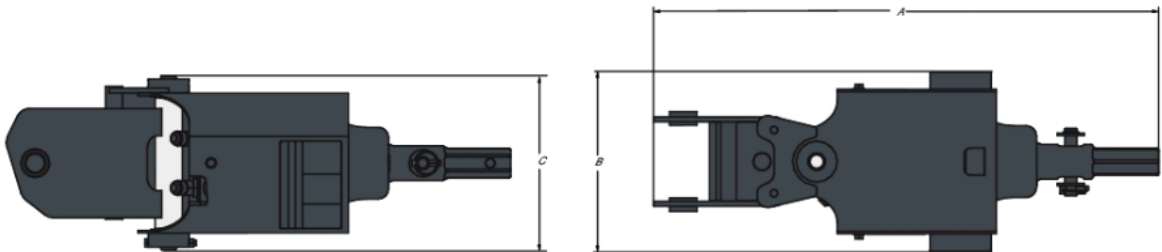

Description	Item number	Operating weight (kg)	Shipping weight (kg)	Overall length (A) (mm)	Overall width (B) (mm)	Overall height (C) (mm)
Auger 15C Unit Drive	6809442	106.0	106.0	269.0	260.0	525.0

# Earth Anchor Installation: Auger Adaptors

## Auger to Earth Anchor and everything in between:

Auger output shafts come in a variety of shapes and sizes; use dimensions A through D to determine if a drive adaptor is required. SunModo offers a variety of drive adaptor solutions which may work for you.

## Auger to Ground Screw:

No adaptor is needed if the output shaft meets these dimensional requirements:

- A: 3.5" or greater
- B: 2-3/8" or less
- C: 2" nominal
- D: 3/4" or greater

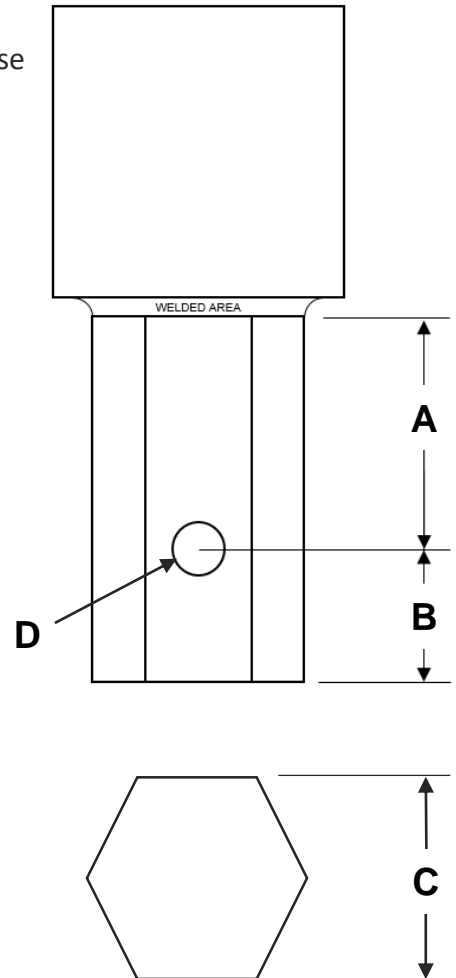

If a custom Auger Adaptor is required, please provide us with the following measurements of the auger drive spindle you will be using:

- A: From bottom of the weld to the center of the drive pin hole.
- B: From the center of the drive pin hole to the bottom of the spindle.
- C: From flat to flat of the hex or square.
- D: The size of the drive pin hole.



# Earth Anchor Installation: Auger Adaptor Solutions

## Skid Steer Output Shaft Dimensions:

### Solution 1:

- A: 3.5" or greater | B: 2-3/8" or less | C: 2" nominal | D: 3/4" or greater
- No Auger Adaptor is required
  - Bobcat 15C fits directly into the SunModo Ground Screws and Augers



### Solution 2:

- A: 3" or greater | B: 2-3/8" or less | C: 2" nominal | D: 3/4" or greater
- K50237-001 SunModo provided H2-RD Lowe Adaptor and 44159 Fastenal 5/8" Hitch Pin
  - H2-RD Lowe Brand Auger Bit Conversion: 2" Hex to 2 9/16" Round Adaptor



### Solution 3:

- A: 3" or greater | B: 2-3/8" or less | C: 2" or 2.5" Hex | D: 3/4" or greater
- K50237-005 SunModo provided AU-002655 Digga Adaptor and 44159 Fastenal 5/8" Hitch Pin
  - AU-002655 Digga Adaptor and 44159 Fastenal 5/8" Hitch Pin

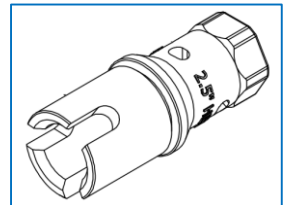

### Solution 4:

- A: 1.5" or greater | B: 2-3/8" or less | C: 2" nominal | D: 3/4" or greater
- Modify the H2-RD Lowe Adaptor by cutting off the top of the adaptor to fit the output shaft of the skid steer.



### Solution 5:

- A: 2.5" or greater | B: 2-3/8" or less | C: 2" nominal | D: 3/4" or greater
- Modify the SunModo Ground Screws and Augers by cutting off up to 1" of the anchor. No auger adaptor is required.

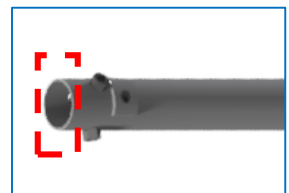

# Earth Anchor Installation: Machine Operated Rotator



## Installation

1. Mark the desired position for installation.
2. Drive the Ground Screw or Auger until it is fully installed.

SunModo Installation Video:

[https://www.youtube.com/watch?time\\_continue=1&v=bzrSjS8oeOM](https://www.youtube.com/watch?time_continue=1&v=bzrSjS8oeOM)

# Earth Anchor Installation: Machine Operated Rotator

## Parts Recommended:

- ✓ Loader or Excavator
- ✓ Bobcat 15C Auger or Auger Adaptor
- ✓ Ground Screws or Blade Augers

