

FLAT PATTERN

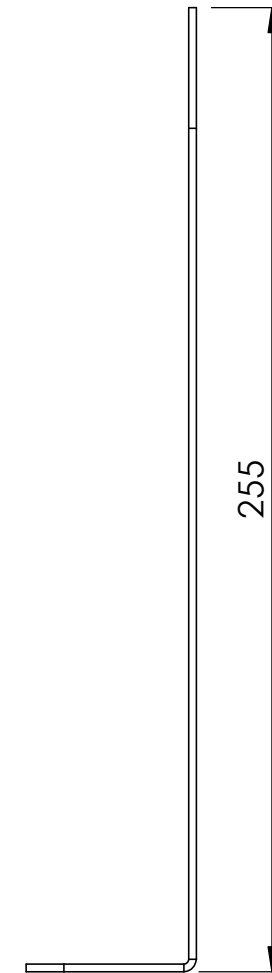
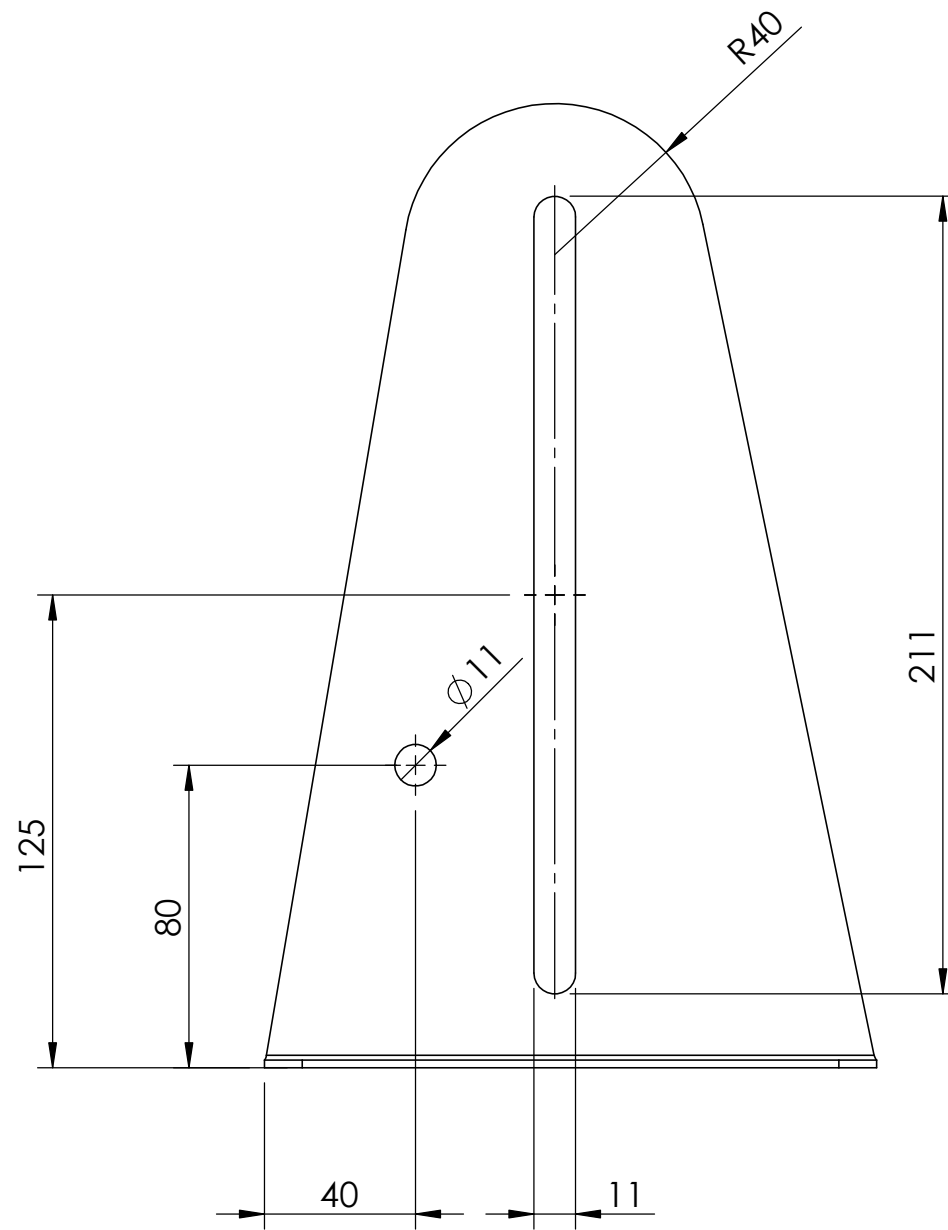
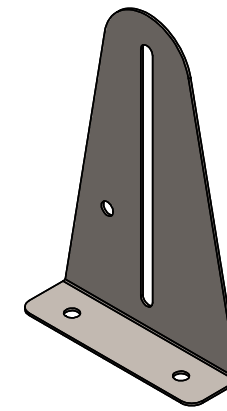

ZONE	REV.	DESCRIPTION	DATE
1		Original Drawing	13/03/2015
REVISIONS			
DWG NO.		CAN-00001	
TITLE:		SOLAR PANEL BRACKETS	

General Tolerance: Linear: ± mm Angular: ± °	INITIALS	SIGNATURE
SCALE: 1:2	DRAWN	DJM
WEIGHT:	APPV'D	

PIONEER
SHEET METAL

MATERIAL:	316L St. St.
THICKNESS:	2.0 mm.
FINISH:	2B

DWG NO. CAN-00001 SHEET 1 OF 1